

Torque Limiter for high-speed applications

*Test equipment
Extruders
Packaging machines
Automated systems
Power transmission*



EAS[®] -Compact Overload Clutches

- *Reliable drive disconnection in case of an overload*
- *Backlash-free torque transmission*
- *Disengaged condition free from residual torque*

www.mayr.de

K.494.01.GB

mayr[®]
power-
transmission

**EAS[®]-Compact,
The effective economic machine protection**

The EAS[®]-Compact underlines once again *mayr*[®]'s position as market and technological leader in the field of mechanical safety clutches. The new EAS[®]-Compact stands for economic and high-quality machine protection with its extremely high efficiency. It is the result of continuous development of the proven *mayr*[®] clutches which are the accepted standard for prevention of costly machine damage.

EAS[®]-Compact clutches provide backlash-free torque transmission during the whole service life and are, therefore, suitable for discriminating and highly dynamic drive concepts.

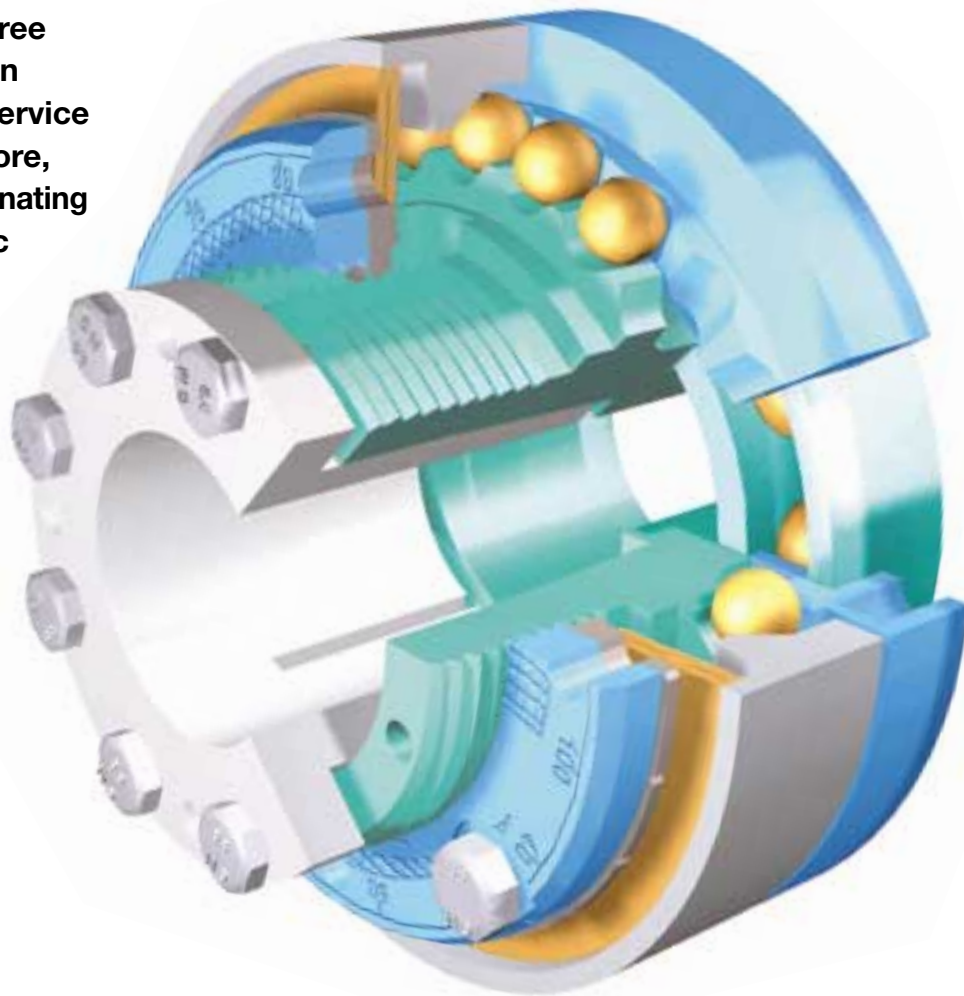

engaged

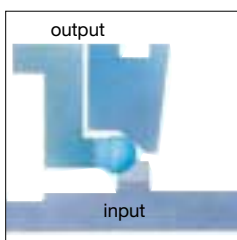

disengaged

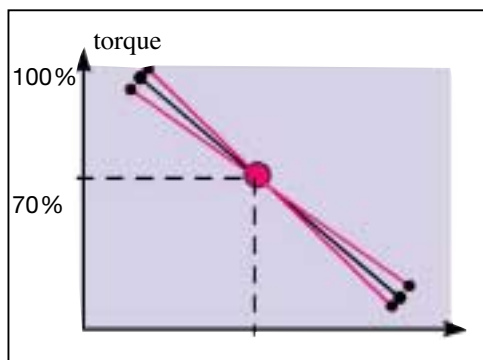
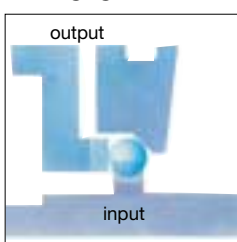

Safe torque adjustment with calibration and percentage scale

EAS[®]-Compact clutches are calibrated to 70 % of the max. torque at the factory. From this ideal datum it is very easy to accurately set the overload torque to other percentage values of the max. torque via the graduated adjusting nut.

Both adjusting nuts - for axial (standard) and radial (option) adjustments - offer this comfortable, safe and readable torque adjustment.

EAS[®]-Compact overload clutch

Summary of types

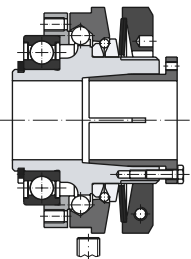
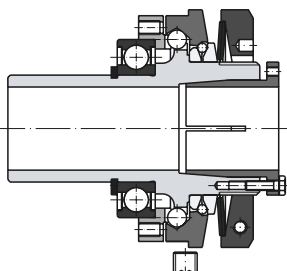
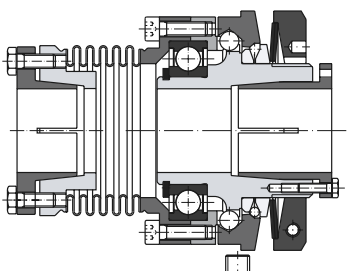
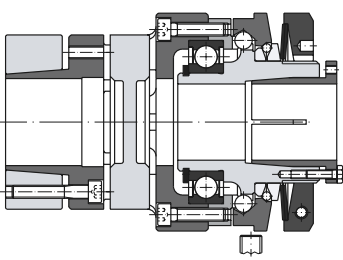
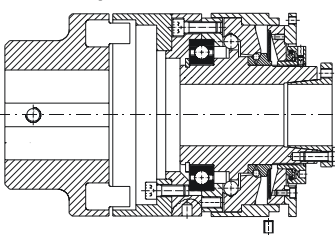
EAS [®] -Compact overload clutch	Type Size	Torque [Nm]	Application	Page
EAS[®]-Compact standard 	490._ 4.0 Sizes 01÷5	5÷2800	Flanged torque limiting clutch for backlash-free torque transmission between shaft and drive element. The torque is transmitted backlash-free until disengagement. Low mass moment of inertia. Long working life. Easy re-engagement.	
			With cone bushing Type 490._ 14.0 Page 4 With keyway Type 490._ 24.0 Page 5	
EAS[®]-Compact With long projecting hub 	490._ 4.1 Sizes 01÷5	5÷2800	Flanged torque limiting clutch for backlash-free torque transmission between shaft and drive element. The torque is transmitted backlash-free until disengagement. Additional location of wide drive elements on a long hub through roll and slide bearing is possible. Low mass moment of inertia. Long working life. Easy re-engagement.	
			With cone bushing Type 490._ 14.1 Page 6 With keyway Type 490._ 24.1 Page 7	
EAS[®]-Compact With steel bellows coupling 	493._ 4.0 Sizes 01÷3	5÷350	Torque limiting clutch for backlash-free torque transmission between two coaxial shafts. The torque is transmitted backlash-free until disengagement. Low mass moment of inertia. Compensates axial, radial and angular misalignments. Long working life. Easy re-engagement.	
			With cone bushing Type 493._ 14.0 Page 8 With keyway Type 493._ 24.0 Page 9 With cone bushing/clamping hub Type 493._ 34.0 Page 10	
EAS[®]-Compact lastic backlash-free 	494._ 4._ Sizes 01÷3	5÷700	Torque limiting clutch for backlash-free torque transmission between two coaxial shafts. The torque is transmitted backlash-free until disengagement. Low mass moment of inertia. Compensates axial, radial and angular misalignments. High damping features - Long working life. Easy re-engagement.	
			With cone bushing/clamping hub Type 494._ 04._ Page 11 With cone bushing/shrink disc Type 494._ 14._ Page 12 With keyway Type 494._ 24._ Page 13	
EAS[®]-Compact lastic 	494._ 4.0 Sizes 4÷5	160÷2800	Torque limiting clutch combined with a torsionally flexible shaft coupling for connection of two shafts. The flexible component is designed as simple plug-in assembly allowing an easy assembly and dismantle of the coupling. Long working life. Easy re-engagement.	
			EAS [®] -side with cone bushing Type 494._ 34.0 Page 14 Both sides with keyway Type 494._ 24.0 Page 14	
Technical explanations Electrical accessories			Limit switch	Page 16

Standard with cone bushing

Type 490._14.0

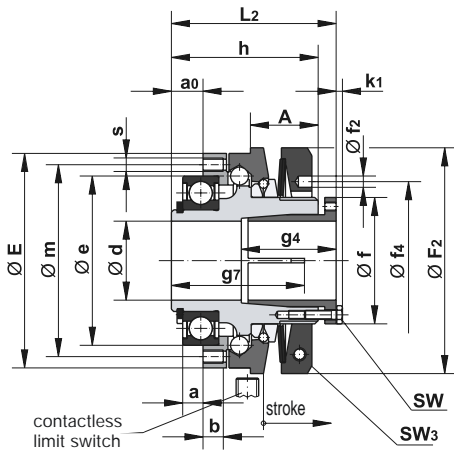

Sizes 01÷3
Type 490._14.0

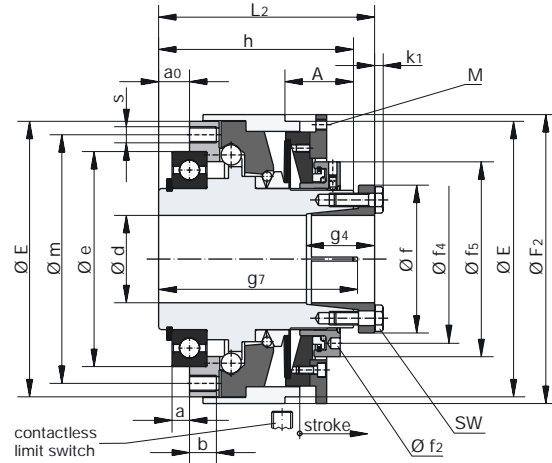

Sizes 4÷5
Type 490._14.0

Technical data

1) Size	Limiting torques for overload M_G 1)			Max. speed n_{max} rpm	Stroke of the thrust washer in the event of an overload mm	Mass moments of inertia I		Weight kg	Screws and tightening torques for			
	Type 490.514.0 Nm	Type 490.614.0 Nm	Type 490.714.0 Nm			Hub side kgm ²	Pressure flange side kgm ²		SW		SW ₃	
	mm		Nm						mm		Nm	
01	5 – 12,5	10 – 25	20 – 50	8000	2,0	0,000383	0,000093	0,92	6 x M4	4	M4	3
0	10 – 25	20 – 50	40 – 100	7000	2,6	0,000943	0,000234	1,55	6 x M4	4	M4	5
1	20 – 50	40 – 100	80 – 200	6000	3,2	0,002279	0,000643	2,58	8 x M4	4	M5	9
2	40 – 100	80 – 200	160 – 400	5000	3,8	0,004421	0,001306	3,70	8 x M5	8	M5	9
3	80 – 175	160 – 350	320 – 700	4000	4,5	0,002649	0,010396	5,83	8 x M6	12	M6	15
4	160 – 350	320 – 700	640 – 1400	3000	5,5	0,11415	0,0258	23,6	8 x M10	40	-	-
5	320 – 700	640 – 1400	1280 – 2800	2000	7,0	0,1827	0,0407	30,4	8 x M12	60	-	-

Size	Bore d 2) 4) from – to mm	Min. shaft length		A	a ⁶⁾	a ₀	b	E	e _{h5} ⁷⁾
		g ₄ mm	g ₇ mm						
01	10 – 20	34	36	24	5	8	6	65	47
0	15 – 25	39	43	28	7	11	7	80	62
1	22 – 35	42	54	30	9	14	9	95	75
2	32 – 45	48	57	34	10	16	10	110	90
3	35 – 55	53	69	40	10	18	12	130	100
4	42 – 65	51	148	51	13	23	20	205	160
5	50 – 75	60	158	54	14	25	22	230	180

Size	F ₂	f	f ₂	f ₄	f ₅	h	k ₁	L ₂ 3)	M	m	s	SW	SW ₃
01	70	38	5	50	-	45	2,8	52	-	56	8 x M4	7	3
0	85	44	5	55	-	55	2,8	63	-	71	8 x M5	7	3
1	100	56	5	70	-	65	2,8	73	-	85	8 x M6	7	4
2	115	70	6	84	-	72	3,5	81	-	100	8 x M6 5)	8	4
3	135	84	7	100	-	82	4	93	-	116	8 x M8 5)	10	5
4	215	110	8	125	145	145	7	161	4 x M8	185	6 x M12	17	-
5	240	124	8	148	165	155	8	175	4 x M10	205	6 x M16	19	-

1) Other sizes for lower and higher torques on request

2) Shaft fits: up to Ø 38 h₆, above Ø 38 h₈

3) Dimensions in an un-tightened condition (in a tightened condition shorter)

4) Transmittable torques with smaller bores on request

We reserve the right to make dimensional and design alterations.

5) For clutch operation in the max. torque range, bolts of the quality class 12.9 must be used for the attachment to the drive element.

6) Mounting tolerance +0,1

7) Fit at customer site H7

Order example:

To be included when ordering, please state:	Size	Type	Bore Ø d	With limit switch
Order number:		490._14.0		see pages 16 - 18

01 ÷ 5 →

* Medium torque range 5 →

* High torque range 6 →

* Max. torque range 7 →

* See technical data, limiting torque for overload M_G

Example: Order number 1 / 490.614.0 / 25 plus limit switch 055.002.5

← According to size

Standard with keyway

Type 490._24.0

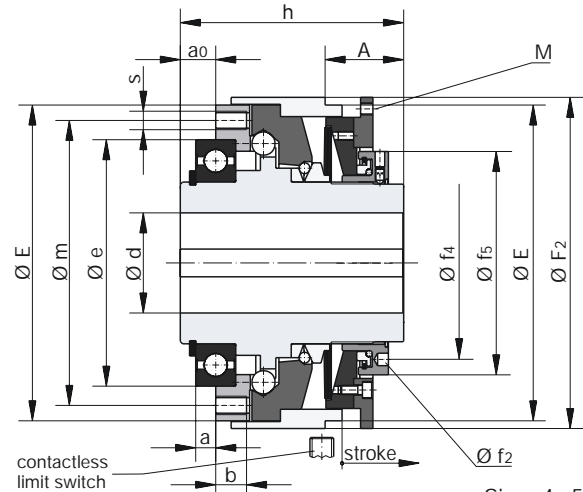
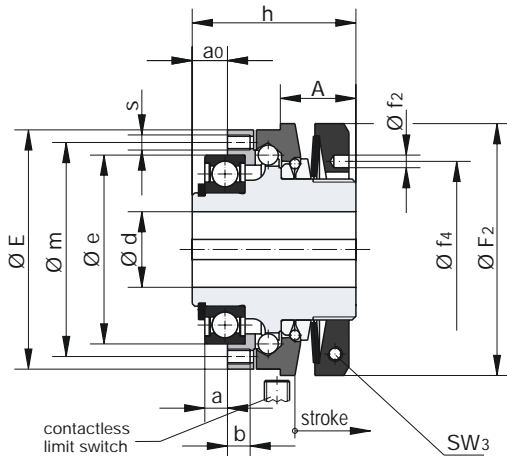

Sizes 01 ÷ 3
Type 490._24.0

Sizes 4 ÷ 5
Type 490._24.0

Technical data

1) Size	Limiting torques for overload M_G 1)			Max. speed n_{max} rpm	Stroke of the thrust washer in the event of an overload mm	Mass moments in inertia I		Weight kg	Screws and tightening torques for SW_3	
	Type 490.524.0 Nm	Type 490.624.0 Nm	Type 490.724.0 Nm			Hub side kgm ²	Pressure flange side kgm ²		SW ₃	
									mm	Nm
01	5 – 12,5	10 – 25	20 – 50	8000	2,0	0,000377	0,000093	0,87	M4	3
0	10 – 25	20 – 50	40 – 100	7000	2,6	0,000917	0,000234	1,43	M4	5
1	20 – 50	40 – 100	80 – 200	6000	3,2	0,002193	0,000643	2,35	M5	9
2	40 – 100	80 – 200	160 – 400	5000	3,8	0,004205	0,001306	3,37	M5	9
3	80 – 175	160 – 350	320 – 700	4000	4,5	0,009867	0,002649	5,31	M6	15
4	160 – 350	320 – 700	640 – 1400	3000	5,5	0,1105	0,0258	23,5	–	–
5	320 – 700	640 – 1400	1400 – 2800	2000	7,0	0,1800	0,0407	29,2	–	–

Size	Bore		A	a ⁵⁾	a ₀	b	E	e _{h5} ⁶⁾
	d _{min} ²⁾ mm	d _{max} ³⁾ mm						
01	12	20	24	5	8	6	65	47
0	15	25	28	7	11	7	80	62
1	22	30	30	9	14	9	95	75
2	28	40	34	10	16	10	110	90
3	32	50	40	10	18	12	130	100
4	40	70	51	13	23	20	205	160
5	45	90	54	14	25	22	230	180

Size	F ₂	f ₂	f ₄	f ₅	h	M	m	s	SW ₃
01	70	5	50	–	45	–	56	8 x M4	3
0	85	5	55	–	55	–	71	8 x M5	3
1	100	5	70	–	65	–	85	8 x M6	4
2	115	6	84	–	72	–	100	8 x M6 ⁴⁾	4
3	135	7	100	–	82	–	116	8 x M8 ⁴⁾	5
4	215	8	125	145	145	4 x M8	185	6 x M12	–
5	240	8	148	165	155	4 x M10	205	6 x M16	–

1) Other sizes for lower and higher torques on request

2) Smaller bores for low torques on request

3) Bigger bores on request

4) For clutch operation in the max. torque range, bolts of the quality class 12.9 must be used for the attachment to the drive element.

5) Mounting tolerance +0,1

6) Fit at customer site H7

We reserve the right to make dimensional and design alterations.

Order example:

To be included when ordering, please state:	Size	Type	Bore $\varnothing d$ H7	With limit switch
Order number:		490._24.0		see pages 16 - 18

01 ÷ 5 →

* Medium torque range 5 →

* High torque range 6 →

* Max. torque range 7 →

* See technical data, limiting torque for overload M_G

← According to size

Example: Order number 1 / 490.624.0 / 25 plus limit switch 055.002.5

Long projecting hub with cone bushing

Type 490_14.1

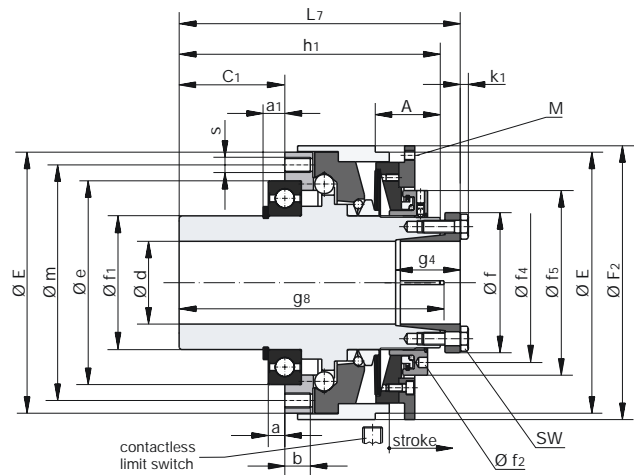
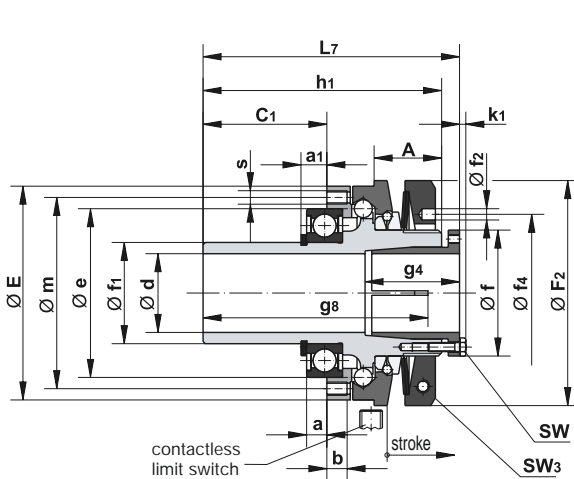

Sizes 01÷3
Type 490_14.1

Sizes 4÷5
Type 490_14.1

Technical data

1) Size	Limiting torques for overload M_G 1)			Max. speed n_{max} rpm	Stroke of the thrust washer in the event of an overload mm	Mass moments of inertia I		Weight kg	Screws and tightening torques for			
	Type 490.514.1 Nm	Type 490.614.1 Nm	Type 490.714.1 Nm			Hub side kgm^2	Pressure flange side kgm^2		SW		SW ₃	
	mm	Nm	mm						Nm	mm	Nm	
01	5 – 12,5	10 – 25	20 – 50	8000	2,0	0,000397	0,000093	1,02	6 x M4	4	M4	3
0	10 – 25	20 – 50	40 – 100	7000	2,6	0,001000	0,000234	1,77	6 x M4	4	M4	5
1	20 – 50	40 – 100	80 – 200	6000	3,2	0,002382	0,000643	2,86	8 x M4	4	M5	9
2	40 – 100	80 – 200	160 – 400	5000	3,8	0,004680	0,001306	4,16	8 x M5	8	M5	9
3	80 – 175	160 – 350	320 – 700	4000	4,5	0,010888	0,002649	6,42	8 x M6	12	M6	15
4	160 – 350	320 – 700	640 – 1400	3000	5,5	0,11588	0,0258	25,9	8 x M10	40	–	–
5	320 – 700	640 – 1400	1400 – 2800	2000	7,0	0,1903	0,0407	33,1	8 x M12	60	–	–

Size	Bore d 2) 4) from – to mm	Min. shaft length		A	a ⁶⁾	a ₁	b	C ₁	E	e _{h5} ⁷⁾
		g ₄ mm	g ₈ mm							
01	10 – 20	34	61	24	5	6,5	6	33	65	47
0	15 – 25	39	75	28	7	8,75	7	43	80	62
1	22 – 35	42	95	30	9	11,5	9	55	95	75
2	32 – 45	48	108	34	10	13	10	67	110	90
3	35 – 55	53	124	40	10	14	12	73	130	100
4	42 – 65	51	208	51	13	17	20	83	205	160
5	50 – 75	60	228	54	14	18	22	95	230	180

Size	F ₂	f	f _{1 h6}	f ₂	f ₄	f ₅	h ₁	k ₁	L ₇ 3)	M	m	s	SW	SW ₃
01	70	38	30	5	50	–	70	2,8	77	–	56	8 x M4	7	3
0	85	44	40	5	55	–	87	2,8	95	–	71	8 x M5	7	3
1	100	56	45	5	70	–	106	2,8	114	–	85	8 x M6	7	4
2	115	70	55	6	84	–	123	3,5	132	–	100	8 x M6 5)	8	4
3	135	84	65	7	100	–	137	4	148	–	116	8 x M8 5)	10	5
4	215	110	105	8	125	125	205	7	221	4 x M8	185	6 x M12	17	–
5	240	124	120	8	148	148	225	8	245	4 x M10	205	6 x M16	19	–

1) Other sizes for lower and higher torques on request

2) Shaft fits: up to Ø 38 h₆, above Ø 38 h₈

3) Dimensions in an un-tightened condition (in a tightened condition shorter)

4) Transmittable torques with smaller bores on request

We reserve the right to make dimensional and design alterations.

5) For clutch operation in the max. torque range, bolts of the quality class 12.9 must be used for the attachment to the drive element.

6) Mounting tolerance +0,1

7) Fit at customer site H7

Order example:

To be included when ordering, please state:	Size	Type	Bore Ø d	With limit switch
Order number:		490_14.1		see pages 16 - 18

01 ÷ 5 →

* Medium torque range 5 →
* High torque range 6 →
* Max. torque range 7 →

* See technical data, limiting torque for overload M_G

← According to size

Example: Order number 1 / 490.614.1 / 25 plus limit switch 055.002.5

EAS[®]-Compact overload clutch

Long projecting hub with keyway

Type 490._24.1

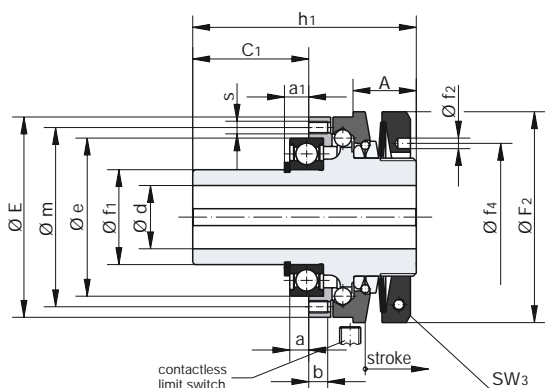

Sizes 01÷3
Type 490._24.1

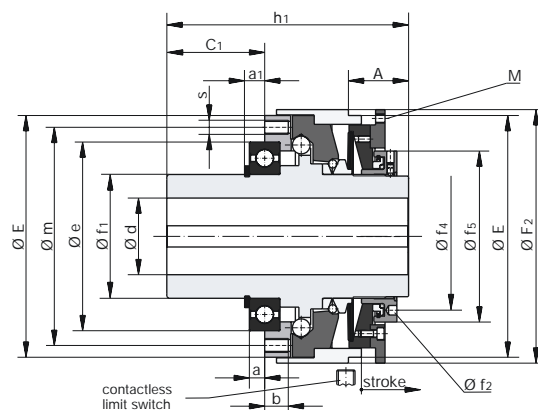

Sizes 4÷5
Type 490._24.1

Technical data

1) Size	Limiting torques for overload M_G 1)			Max. speed n_{max} rpm	Stroke of the thrust washer in the event of an overload mm	Mass moments of inertia I		Weight kg	Screws and tightening torques for	
	Type 490.524.1 Nm	Type 490.624.1 Nm	Type 490.724.1 Nm			Hub side kgm ²	Pressure flange side kgm ²		SW ₃	
			mm						Nm	
01	5 – 12,5	10 – 25	20 – 50	8000	2,0	0,000391	0,000093	0,97	M4	3
0	10 – 25	20 – 50	40 – 100	7000	2,6	0,000974	0,000234	1,65	M4	5
1	20 – 50	40 – 100	80 – 200	6000	3,2	0,002296	0,000643	2,64	M5	9
2	40 – 100	80 – 200	160 – 400	5000	3,8	0,004464	0,001306	3,82	M5	9
3	80 – 175	160 – 350	320 – 700	4000	4,5	0,010389	0,002649	5,90	M6	15
4	160 – 350	320 – 700	640 – 1400	3000	5,5	0,11224	0,0258	25,8	–	–
5	320 – 700	640 – 1400	1400 – 2800	2000	7,5	0,1876	0,0407	31,9	–	–

Size	Bore		A	a ⁵⁾	a ₁	b	C ₁	E	e _{h5} ⁶⁾
	d _{min} ²⁾ mm	d _{max} ³⁾ mm							
01	12	20	24	5	6,5	6	33	65	47
0	15	25	28	7	8,75	7	43	80	62
1	22	30	30	9	11,5	9	55	95	75
2	28	40	34	10	13	10	67	110	90
3	32	50	40	10	14	12	73	130	100
4	40	70	51	13	17	20	83	205	160
5	45	90	54	14	18	22	95	230	180

Size	F ₂	f _{1 h6}	f ₂	f ₄	f ₅	h ₁	M	m	s	SW ₃
01	70	30	5	50	–	70	–	56	8 x M4	3
0	85	40	5	55	–	87	–	71	8 x M5	3
1	100	45	5	70	–	106	–	85	8 x M6	4
2	115	55	6	84	–	123	–	100	8 x M6 ⁴⁾	4
3	135	65	7	100	–	137	–	116	8 x M8 ⁴⁾	5
4	215	105	8	125	145	205	4 x M8	185	6 x M12	–
5	240	120	8	148	165	225	4 x M10	205	6 x M16	–

1) Other sizes for lower and higher torques on request

2) Smaller bores for low torques on request

3) Bigger bores on request

4) For clutch operation in the max. torque range, bolts of the quality class 12.9 must be used for the attachment to the drive element.

5) Mounting tolerance +0,1

6) Fit at customer site H7

We reserve the right to make dimensional and design alterations.

Order example:

To be included when ordering, please state:	Size	Type	Bore Ø d ^{H7}	With limit switch
Order number:		490._24.1		see pages 16 - 18

01 ÷ 5 →

* Medium torque range 5 →

* High torque range 6 →

* Max. torque range 7 →

* See technical data, limiting torque for overload M_G

← According to size

Example: Order number 1 / 490.624.1 / 25 plus limit switch 055.002.5

Steel bellows with cone bushing

Type 493._14.0

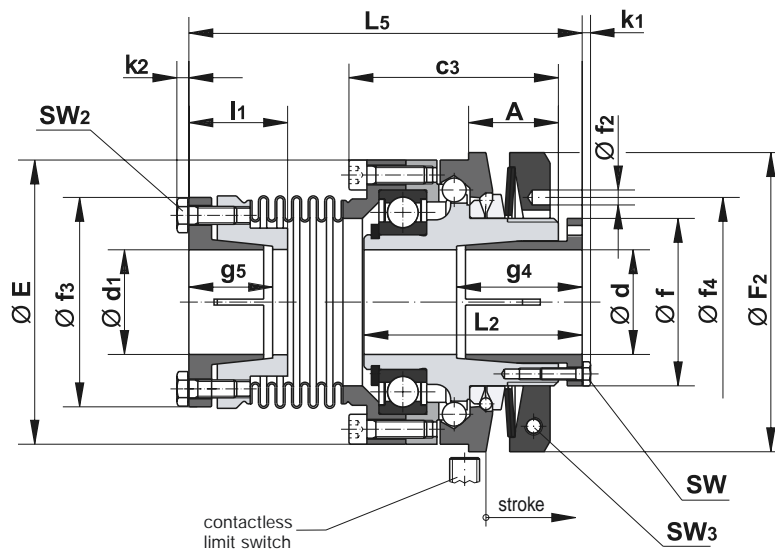

Sizes 01÷3
Type 493._14.0

Technical data

Size	Limiting torques for overload M_G ¹⁾		Nominal torque of flexible, torsionally rigid steel bellows coupling T_{KN} Nm	Max. Speed n_{max} rpm	Stroke of the thrust washer in the event of an overload mm	Permissible flexibility		
	Type 493.514.0 Nm	Type 493.614.0 Nm				axial ΔK_a mm	angular ΔK_w °	radial ΔK_r mm
01	5 – 12,5	10 – 25	50	8000	2,0	0,4	2	0,15
0	10 – 25	20 – 50	100	7000	2,6	0,6	2	0,15
1	20 – 50	40 – 100	200	6000	3,2	0,8	2	0,20
2	40 – 100	80 – 200	350	5000	3,8	1,0	2	0,25
3	80 – 175	160 – 350	600	4000	4,5	1,0	2	0,30

Size	Mass moments of inertia I		Weight kg	Clamping bolts and tightening torques SW						Bore ^{2) 4)}		Min. shaft length	
	Hub side kgm ²	Flexible side kgm ²		SW mm		SW ₂ Nm		SW ₃ Nm		d from - to mm	d ₁ from - to mm	g ₄ mm	g ₅ mm
01	0,000383	0,000233	1,33	6 x M4	4	4 x M4	3	M4	3	10 – 20	9 – 20	34	24
0	0,000943	0,000664	2,29	6 x M4	4	6 x M5	5	M4	5	15 – 25	12 – 25	39	27
1	0,002279	0,001583	3,68	8 x M4	4	6 x M6	9,5	M5	9	22 – 35	15 – 35	42	29
2	0,004421	0,003276	5,42	8 x M5	8	6 x M8	17	M5	9	32 – 45	22 – 42	48	32
3	0,010396	0,007079	8,43	8 x M6	12	8 x M8	17	M6	15	35 – 55	32 – 50	53	35

Size	A	c ₃	E	F ₂	f	f ₂	f ₃	f ₄	k ₁	k ₂	L ₂ ³⁾	L ₅ ³⁾	l ₁ ³⁾	SW	SW ₂	SW ₃
01	24	50	65	70	38	5	47	50	2,8	2,8	52	98	27,5	7	7	3
0	28	60	80	85	44	5	60	55	2,8	3,5	63	116	29	7	7	3
1	30	70	95	100	56	5	70	70	2,8	4,0	73	131,5	33	7	8	4
2	34	78	110	115	70	6	81	84	3,5	5,3	81	147	37	8	10	4
3	40	88	130	135	84	7	98	100	4,0	5,3	93	171	45	10	13	5

1) Other sizes for lower and higher torques on request

We reserve the right to make dimensional and design alterations.

2) Shaft fits: up to Ø 38 _{H6}, above Ø 38 _{H8}

3) Dimensions in an un-tightened condition (in a tightened condition shorter)

4) Transmittable torques with smaller bores on request

Order example:

To be included when ordering, please state:	Size	Type	Bore Ø d	Bore Ø d ₁	With limit switch
Order number:		493._14.0			see pages 16 - 18

01 ÷ 3 →

* Medium torque range → 5

* High torque range → 6

← According to size

← According to size

* See technical data, limiting torque for overload M_G

Example: Order number 1 / 493.614.0 / 22 / 25 plus limit switch 055.002.5

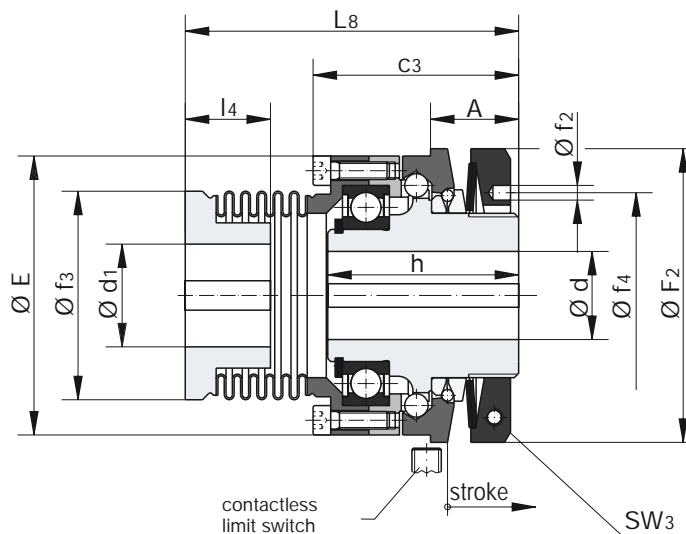

Sizes 01 ÷ 3
Type 493._24.0

Technical data

Size	Limiting torques for overload M_G ¹⁾		Nominal torque of flexible, torsionally rigid steel bellows coupling T_{KN} Nm	Max. Speed n_{max} rpm	Stroke of the thrust washer in the event of an overload mm	Permissible flexibility			Screws and tightening torques for SW_3	
	Type 493.524.0	Type 493.624.0				axial ΔK_a	angular ΔK_w	radial ΔK_r		
	Nm	Nm				mm	°	mm	mm	Nm
01	5 – 12,5	10 – 25	50	8000	2,0	0,4	2	0,15	M4	3
0	10 – 25	20 – 50	100	7000	2,6	0,6	2	0,15	M4	5
1	20 – 50	40 – 100	200	6000	3,2	0,8	2	0,20	M5	9
2	40 – 100	80 – 200	350	5000	3,8	1,0	2	0,25	M5	9
3	80 – 175	160 – 350	600	4000	4,5	1,0	2	0,30	M6	15

Size	Mass moments of inertia I		Weight kg	Bore			
	Hub side kgm ²	Flexible side kgm ²		d_{min} mm	d_{max} mm	$d_{1 min}$ mm	$d_{1 max}$ mm
01	0,000383	0,000233	1,28	9	20	9	20 ²⁾
0	0,000943	0,000664	2,17	12	25	12	25 ³⁾
1	0,002279	0,001583	3,45	15	30	15	35 ⁴⁾
2	0,004421	0,003276	5,09	22	40	22	42 ⁵⁾
3	0,010396	0,007079	8,14	32	50	32	50

Size	A	C ₃	E	F ₂	f ₂	f ₃	f ₄	h	L ₈	l ₄	SW ₃
01	24	50	65	70	5	47	50	45	82,5	25	3
0	28	60	80	85	5	60	55	55	99	27	3
1	30	70	95	100	5	71	70	65	113,5	29	4
2	34	78	110	115	6	81	84	72	126	36	4
3	40	88	130	135	7	98	100	82	147,5	44	5

1) Other sizes for lower and higher torques on request
 2) Up to Ø 18 keyway DIN 6885/1, above Ø 18 keyway DIN 6885/3
 3) Up to Ø 22 keyway DIN 6885/1, above Ø 22 keyway DIN 6885/3
 4) Up to Ø 33 keyway DIN 6885/1, above Ø 33 keyway DIN 6885/3
 5) Up to Ø 38 keyway DIN 6885/1, above Ø 38 keyway DIN 6885/3

We reserve the right to make dimensional and design alterations.

Order example:

To be included when ordering, please state:	Size	Type	Bore Ø d	Bore Ø d ₁ ^{H7}	With limit switch
Order number:		4 9 3 . _ 2 4 . 0			see pages 16 - 18

01 ÷ 3 →
 * Medium torque range 5 →
 * High torque range 6 →

← According to size
 ← According to size

* See technical data, limiting torque for overload M_G

Example: Order number 2 / 493.624.0 / 22 / 25 plus limit switch 055.002.5

EAS[®]-Compact with steel bellows coupling
EAS[®]-side cone bushing
Coupling-side clamping hub

Type 493._34.0

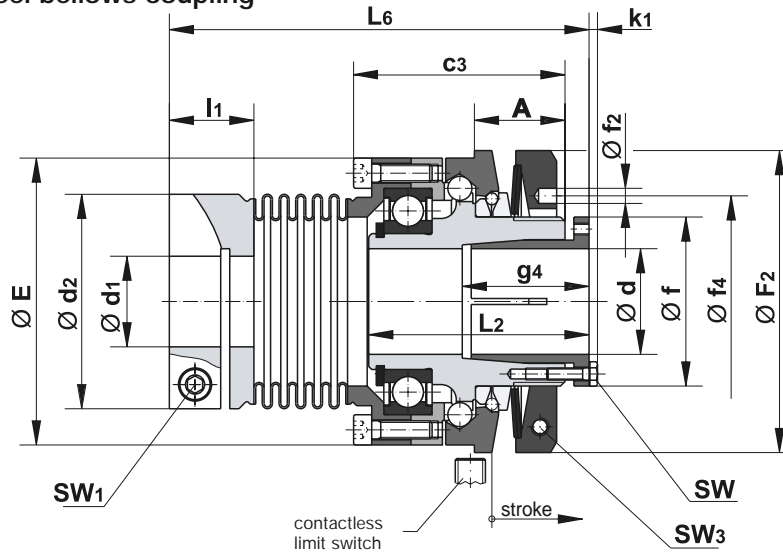

Sizes 01 ÷ 3
Type 493._34.0

Technical data

Size	Limiting torques for overload M_G ¹⁾		Nominal torque of flexible, torsionally rigid steel bellows coupling T_{KN} Nm	Max. speed n_{max} rpm	Stroke of the thrust washer in the event of an overload mm	Permissible flexibility		
	Type 493.534.0 Nm	Type 493.634.0 Nm				axial ΔK_a mm	angular ΔK_w °	radial ΔK_r mm
01	5 – 12,5	10 – 25	50	8000	2,0	0,4	2	0,15
0	10 – 25	20 – 50	100	7000	2,6	0,6	2	0,15
1	20 – 50	40 – 100	200	6000	3,2	0,8	2	0,20
2	40 – 100	80 – 200	350	5000	3,8	1,0	2	0,25
3	80 – 175	160 – 350	600	4000	4,5	1,0	2	0,30

Size	Mass moments of inertia I		Weight kg	Clamping bolts and tightening torques						Bore ^{2) 4)}		Min. shaft length	
	Hub side kgm ²	Flexible side kgm ²		SW		SW ₁		SW ₃		d from - to mm	d ₁ from - to mm	g ₄ mm	l ₁ mm
01	0,000383	0,000233	1,46	6 x M4	4	M 5	10	M4	3	10 – 20	12 – 25	34	24
0	0,000943	0,000664	2,32	6 x M4	4	M 6	18	M4	5	15 – 25	15 – 32	39	28
1	0,002279	0,001583	3,70	8 x M4	4	M 6	18	M5	9	22 – 35	25 – 42	42	28
2	0,004421	0,003276	5,47	8 x M5	8	M 8	43	M5	9	32 – 45	30 – 45	48	36
3	0,010396	0,007079	8,36	8 x M6	12	M10	87	M6	15	35 – 55	35 – 55	53	40

Size	A	c ₃	d ₂	E	F ₂	f	f ₂	f ₄	k ₁	L ₂	L ₆ ³⁾	SW	SW ₁	SW ₃
01	24	50	50	65	70	38	5	50	2,8	52	107	7	4	3
0	28	60	60	80	85	44	5	55	2,8	63	126	7	5	3
1	30	70	71	95	100	56	5	70	2,8	73	139	7	5	4
2	34	78	82	110	115	70	6	84	3,5	81	159	8	6	4
3	40	88	98	130	135	84	7	100	4,0	93	184	10	8	5

1) Other sizes for lower and higher torques on request. We reserve the right to make dimensional and design alterations.
 2) Shaft fits: up to Ø 38 _{H6}, above Ø 38 _{H8}
 3) Dimensions in an un-tightened condition (in a tightened condition shorter)
 4) Transmittable torques with smaller bores on request

Order example:

To be included when ordering, please state:	Size	Type	Bore Ø d	Bore Ø d ₁ ^{H7}	With limit switch
Order number:		4 9 3 . _ 3 4 . 0			see pages 16 - 18

01 ÷ 3 →
 * Medium torque range 5 →
 * High torque range 6 →

← According to size
 ← According to size

* See technical data, limiting torque for overload M_G

Example: Order number 0 / 493.634.0 / 22 / 25 plus limit switch 055.002.5

EAS®-Compact overload clutch

EAS®-Compact with flexible, backlash-free shaft coupling
 EAS®-side cone bushing
 Coupling-side shrink disc

Type 494._14._

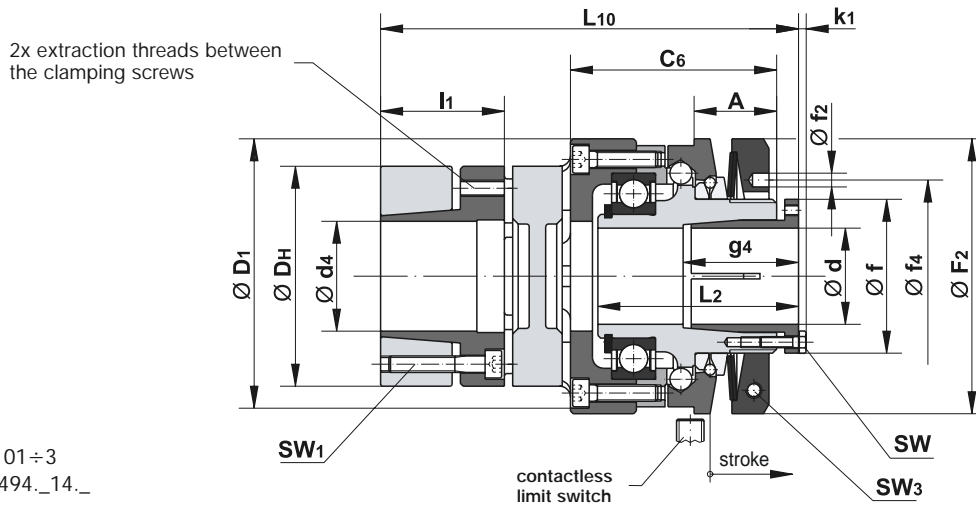

Sizes 01 ÷ 3
 Type 494._14._

Technical data

Size	Limiting torques for overload M_G			Nominal torque flexible, backlash-free shaft coupling $T_{KN}^{(1)}$				Max. speed n_{max} rpm	Stroke of the thrust washer in the event of an overload mm	Screws and tightening torques for						Weight kg
	Type 1) 494.514._	Type 1) 494.614._	Type 1) 494.714._	92 Shore A		98 Shore A				SW		SW ₁		SW ₃		
	Nm	Nm	Nm	T_{KN} Nm	$T_{KN max}$ Nm	T_{KN} Nm	$T_{KN max}$ Nm			mm	Nm	mm	Nm	mm	Nm	
01	5 – 12,5	10 – 25	20 – 50	35	70	60	120	8000	2,0	6xM4	4	4xM5	6	M4	3	1,58
0	10 – 25	20 – 50	40 – 100	95	190	160	320	7000	2,6	6xM4	4	8xM5	6	M4	5	2,62
1	20 – 50	40 – 100	80 – 200	190	380	325	650	6000	3,2	8xM4	4	8xM6	10,5	M5	9	4,45
2	40 – 100	80 – 200	160 – 400	265	530	450	900	5000	3,8	8xM5	8	4xM8	25	M5	9	6,86
3	80 – 175	160 – 350	-	310	620	525	1050	4000	4,5	8xM6	12	4xM8	30	M6	15	11,22

Size	Shaft misalignments flexible coupling					Mass moments of inertia I		Bores		Min. shaft length 94 mm
	Axial 92/98 Shore A ΔK_a mm	Radial 92 Shore A ΔK_r mm		Angular misalignments 92 Shore A α °		Hub side kgm ²	Flexible side kgm ²	Flexible side $\varnothing d_4^{1)}$ mm	EAS®-side $\varnothing d^{2) 3)}$ mm	
	92 Shore A ΔK_r mm	98 Shore A ΔK_r mm	92 Shore A α °	98 Shore A α °						
01	1,4	0,14	0,10	1,0	0,9	0,000383	0,0004	15 – 28	10 – 20	34
0	1,5	0,15	0,11	1,0	0,9	0,000943	0,0010	18 – 38	15 – 25	39
1	1,8	0,17	0,12	1,0	0,9	0,002279	0,0020	20 – 45	22 – 35	42
2	2,0	0,19	0,14	1,0	0,9	0,004421	0,0050	28 – 50	32 – 45	48
3	2,1	0,21	0,16	1,0	0,9	0,010396	0,0114	35 ⁴⁾ – 60	35 – 55	53

Size	A	C ₆	D ₁	D _H	F ₂	f	f ₂	f ₄	k ₁	L ₂ ⁶⁾	L ₁₀ ⁶⁾	I ₁	SW	SW ₁	SW ₃
01	24	52	70	55	70	38	5	50	2,8	52	107	30	7	4	3
0	28	63,5	85	65	85	44	5	55	2,8	63	126,5	35	7	4	3
1	30	75	100	80	100	56	5	70	2,8	73	152	45	7	5	4
2	34	82	115	95	115	70	6	84	3,5	81	167	50	8	6	4
3	40	94	135	105	135	84	7	100	4,0	93	189	56	8	8	5

1) The transmittable torques of the flex. coupling „TKN“ are dependent on factors as for example temperature factor, torsional rigidity factor etc., see also coupling design ROBA®-ES catalogue K.940 or please contact our sales office. Furthermore the transmittable torques of the flexible coupling depend on the bore diameter d_3 , see also table 1 on page 18, cat. 490
 2) Shaft fits: up to $\varnothing 38_{h6}$, above $\varnothing 38_{h8}$
 3) Transmittable torques with smaller bores on request
 4) Shaft fits: up to $\varnothing 40_{j6}$
 6) Dimensions in an un-tightened condition (in a tightened condition shorter)
 We reserve the right to make dimensional and design alterations.

Order example:

To be included when ordering, please state:	Size	Type	Bore $\varnothing d$	Bore $\varnothing d_4$	With limit switch
Order number:		494._14._			see pages 16 - 18

01 ÷ 3 →
 * Medium torque range 5 →
 * High torque range 6 →
 * Max. torque range 7 →
 * See technical data, limiting torque for overload M_G
 ← According to size
 ← According to size
 ← 3 Flex. coupling 92 shore A
 ← 4 Flex. coupling 98 shore A

Example: Order number 1 / 494.614.3 / 22 / 25 plus limit switch 055.002.5

EAS[®]-Compact with flexible, backlash-free shaft coupling
EAS[®]-side cone bushing
lastic - side clamping hub

Type 494._04._

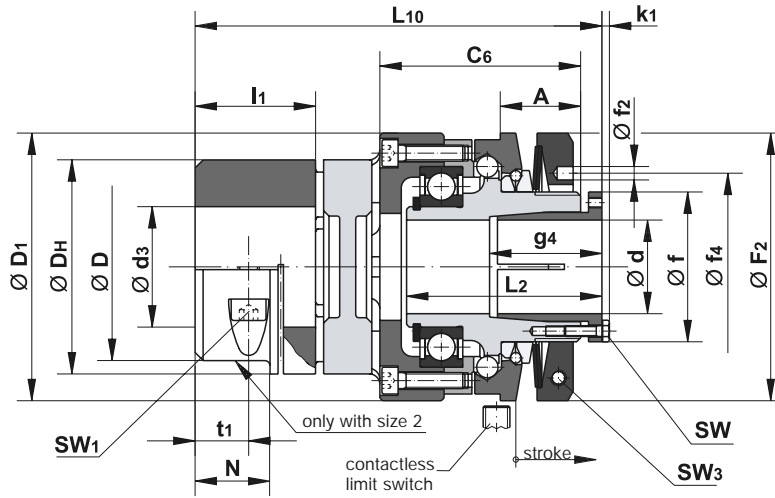

Sizes 01 ÷ 3
Type 494._0._

Technical data

Size	Limiting torques for overload M_G			Nominal torque flexible, backlash-free shaft coupling $T_{KN}^{1)}$				Max. speed n_{max} rpm	Stroke of the thrust washer in the event of an overload mm	Screws and tightening torques for						Weight kg
	Type 1) 494.504._ Nm	Type 1) 494.604._ Nm	Type 1) 494.704._ Nm	92 Shore A T_{KN} Nm	92 Shore A $T_{KN max}$ Nm	98 Shore A T_{KN} Nm	98 Shore A $T_{KN max}$ Nm			SW		SW ₁		SW ₃		
01	5 – 12,5	10 – 25	20 – 50	35	70	60	120	8000	2,0	6 x M4	4	M 6	10	M4	3	1,58
0	10 – 25	20 – 50	40 – 100	95	190	160	320	7000	2,6	6 x M4	4	M 8	25	M4	5	2,62
1	20 – 50	40 – 100	80 – 200	190	380	325	650	6000	3,2	8 x M4	4	M 8	25	M5	9	4,45
2	40 – 100	80 – 200	–	265	530	450	900	5000	3,8	8 x M5	8	M 8	25	M5	9	6,86
3	80 – 175	160 – 350	–	310	620	525	1050	4000	4,5	8 x M6	12	M12	90	M6	15	11,22

Size	Shaft misalignments flexible coupling					Mass moments of inertia I		Bores		Min. shaft length 94 mm
	Axial 92/98 Shore A ΔK_a mm	Radial 92 Shore A ΔK_r mm	Radial 98 Shore A ΔK_r mm	Angular misalignments 92 Shore A α ° / 98 Shore A α °		Hub side kgm ²	Flexible side kgm ²	Flexible side $\varnothing d_3^{1)}$ mm	EAS [®] -side $\varnothing d^{2) 3)}$ mm	
	01	1,4	0,14	0,10	1,0	0,9	0,000383	0,0004	15 – 28	
0	1,5	0,15	0,11	1,0	0,9	0,000943	0,0010	19 – 35	15 – 25	39
1	1,8	0,17	0,12	1,0	0,9	0,002279	0,0020	20 – 45	22 – 35	42
2	2,0	0,19	0,14	1,0	0,9	0,004421	0,0050	28 – 45	32 – 45	48
3	2,1	0,21	0,16	1,0	0,9	0,010396	0,0114	35 – 55	35 – 55	53

Size	A	C ₆	D	D ₁	D _H	F ₂	f	f ₂	f ₄	k ₁	L ₂ ⁶⁾	L ₁₀ ⁶⁾	I ₁	N	t ₁	SW	SW ₁	SW ₃
01	24	52	–	70	55	70	38	5	50	2,8	52	107	30	–	12	7	5	3
0	28	63,5	–	85	65	85	44	5	55	2,8	63	126,5	35	–	13,5	7	6	3
1	30	75	–	100	80	100	56	5	70	2,8	73	152	45	–	20	7	6	4
2	34	82	75	115	95	115	70	6	84	3,5	81	167	50	28	20	8	6	4
3	40	94	–	135	105	135	84	7	100	4,0	93	189	56	–	21	8	8	5

1) The transmittable torques of the flex. coupling „TKN“ are dependent on factors as for example temperature factor, torsional rigidity factor etc., see also coupling design ROBA[®]-ES catalogue K.940 or please contact our sales office. Furthermore the transmittable torques of the flexible coupling depend on the bore diameter d_3 , see also table 1 on page 18, cat. 490
 2) Shaft fits: up to $\varnothing 38_{p6}$, above $\varnothing 38_{p8}$
 3) Transmittable torques with smaller bores on request
 6) Dimensions in an un-tightened condition (in a tightened condition shorter)
 We reserve the right to make dimensional and design alterations.

Order example:

To be included when ordering, please state:	Size	Type	Bore $\varnothing d$	Bore $\varnothing d_{3 H7}$	With limit switch
Order number:		4 9 4 . _ 0 4 . _			see pages 16 - 18

01 ÷ 3 →
 * Medium torque range 5 →
 * High torque range 6 →
 * Max. torque range 7 →
 * See technical data, limiting torque for overload M_G
 ← According to size
 ← According to size
 ← 3 Flex. coupling 92 shore A
 ← 4 Flex. coupling 98 shore A

Example: Order number 1 / 494.604.3 / 22 / 25 plus limit switch 055.002.5

EAS®-Compact overload clutch

EAS®-Compact with flexible, backlash-free shaft coupling
 EAS®-side keyway
 lastic - side keyway

Type 494._24._

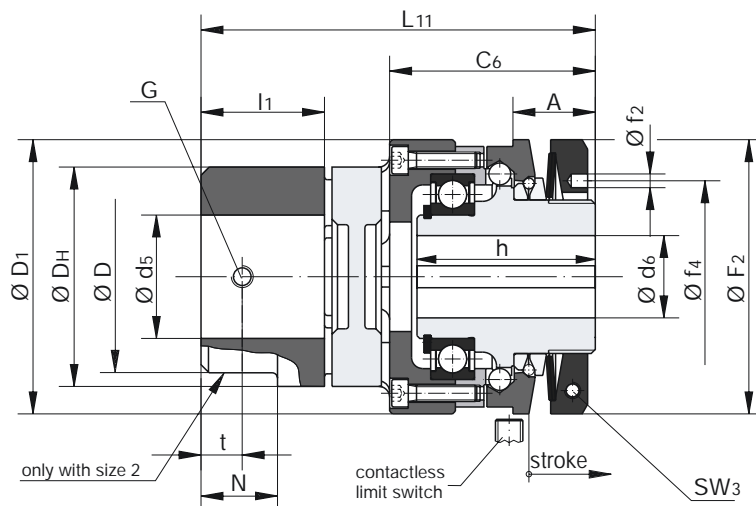

Sizes 01÷3
 Type 494._24._

Technical data

Size	Limiting torques for overload M_G			Nominal torque flexible, backlash-free shaft coupling $T_{KN}^{1)}$				Max. Speed n_{max} rpm	Stroke of the thrust washer in the event of an overload mm	Weight kg	Screws and tightening torques for	
	Type 1) 494.524._	Type 1) 494.624._	Type 1) 494.724._	92 Shore A		98 Shore A					SW ₃	
	Nm	Nm	Nm	T_{KN} Nm	$T_{KN max}$ Nm	T_{KN} Nm	$T_{KN max}$ Nm				mm	Nm
01	5 – 12,5	10 – 25	20 – 50	35	70	60	120	8000	2,0	1,50	M4	3
0	10 – 25	20 – 50	40 – 100	95	190	160	320	7000	2,6	2,50	M4	5
1	20 – 50	40 – 100	80 – 200	190	380	325	650	6000	3,2	4,22	M5	9
2	40 – 100	80 – 200	160 – 400	265	530	450	900	5000	3,8	6,52	M5	9
3	80 – 175	160 – 350	320 – 700	310	620	525	1050	4000	4,5	10,80	M6	15

Size	Shaft misalignments flexible coupling					Mass moments of inertia I		Bores	
	Axial 92/98 Shore A ΔK_a mm	Radial 92 Shore A ΔK_r mm		Angular misalignments 92 Shore A α °		Hub side kgm ²	Flexible side kgm ²	Flexible Side $\varnothing d_5$ mm	EAS® side $\varnothing d_6^{5) 6)}$ mm
		92 Shore A	98 Shore A	92 Shore A	98 Shore A				
01	1,4	0,14	0,10	1,0	0,9	0,000383	0,0004	8 – 28	12 – 20
0	1,5	0,15	0,11	1,0	0,9	0,000943	0,0010	10 – 38	15 – 25
1	1,8	0,17	0,12	1,0	0,9	0,002279	0,0020	12 – 45	22 – 30
2	2,0	0,19	0,14	1,0	0,9	0,004421	0,0050	14 – 55	28 – 40
3	2,1	0,21	0,16	1,0	0,9	0,010396	0,0114	20 – 60	32 – 50

Size	A	C ₆	D	D ₁	D _H	F ₂	f ₂	f ₄	G	h	L ₁₁	I ₁	N	t	SW ₃
01	24	52	–	70	55	70	5	50	M5	45	100	30	–	10	3
0	28	63,5	–	85	65	85	5	55	M6	55	118,5	35	–	15	3
1	30	75	–	100	80	100	5	70	M8	65	144	45	–	15	4
2	34	82	75	115	95	115	6	84	M8	72	158	50	28	20	4
3	40	94	–	135	105	135	7	100	M8	82	178	56	–	25	5

1) The transmittable torques of the flex. coupling „TKN“ are dependent on factors as for example temperature factor, torsional rigidity factor etc., see also coupling design ROBA®-ES catalogue K.940 or please contact our sales office.

5) Smaller bores for lower torques on request

6) Larger bores on request

We reserve the right to make dimensional and design alterations.

Order example:

To be included when ordering, please state:	Size	Type	Bore $\varnothing d_6^{H7}$	Bore $\varnothing d_5^{H7}$	With limit switch
Order number:		4 9 4 . _ 2 4 . _			see pages 16 - 18

01 ÷ 3 →

* Medium torque range → 5

* High torque range → 6

* Max. torque range → 7

* See technical data, limiting torque for overload M_G

← According to size

← According to size

← 3 Flex. coupling 92 shore A

← 4 Flex. coupling 98 shore A

Example: Order number 1 / 494.624.3 / 22 / 25 plus limit switch 055.002.5

EAS[®]-Compact lastic

Type 494.__4.0

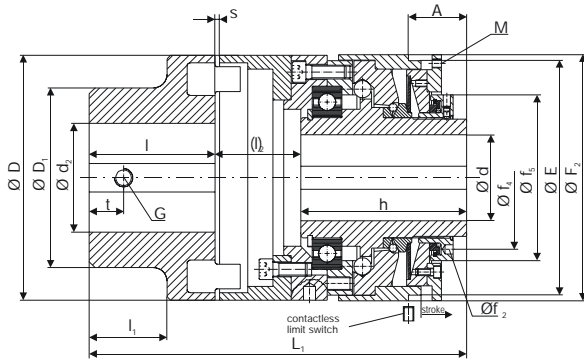

Type 494._24.0
keyway on both sides

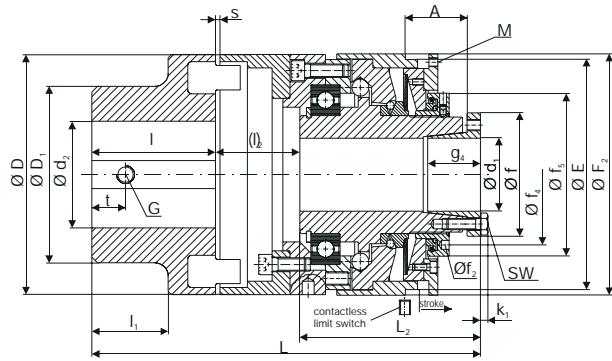

Type 494._34.0
EAS[®]-side cone bushing
lastic-side keyway

Technical data

Size	Limiting torques for overload M_G			Nominal torque of flexible torsionally coupling T_{KN}	Max. Speed n_{max}	Stroke of the thrust washer in the event of overload	Permissible flexibility		
	Type 494.5_4.0 Nm	Type 494.6_4.0 Nm	Type 494.7_4.0 Nm				axial ΔK_a	angular ΔK_w	radial ΔK_r
				Nm	rpm	mm	mm	°	mm
4	160 – 350	320 – 700	640 – 1400	1500	3000	5,5	± 2	0,8	0,7
5	320 – 400	640 – 1400	1400 – 2800	2400	2000	7,0	± 2	0,8	0,7

Size	Mass moments of inertia I		Weight	Bore						Bolts and tightening torques for SW	
	Hub side kgm^2	Flexible side kgm^2		d_{min} mm	d_{max} mm	$d_{1 min}$ mm	$d_{1 max}$ mm	$d_{2 min}$ mm	$d_{2 max}$ mm	mm	Nm
	0,11	0,20	52,6	40	70	42	65	58	95	8 x M 10	40
	0,18	0,32	66,9	45	90	50	75	65	110	8 x M 12	60

Size	A	D	D ₁	E	F ₂	f	f ₂	f ₄	f ₅	G	g ₄	h
4	51	214	157	205	215	110	8	125	145	M 16	51	145
5	54	240	179	230	240	124	8	148	165	M 16	60	155

Size	k ₁	L ¹⁾	L ₁	L ₂ ¹⁾	l	l ₁	l ₂	M	t	s	SW
4	7	346	330	161	110	68	75	4 x M 8	30	4	17
5	8	370	358	175	120	75	75	4 x M 10	35	4	19

1) Dimensions in an un-tightened condition (in a tightened condition shorter)

We reserve the right to make dimensional and design alterations.

Order example:

To be included when ordering, please state:	Size	Type	Bore $\varnothing d$	Bore $\varnothing d_1$	Bore $\varnothing d_2$	With limit switch
Order number:		4 9 4 . __ 4 . 0				see pages 16 - 18

- 4 ÷ 5 →
- * Medium torque range 5 →
- * High torque range 6 →
- * Max. torque range 7 →
- * see technical data, limiting for overload M_G
- According to size
- According to size
- According to size
- 2 ... keyway on both sides
- 3 ... EAS[®]-side cone bushing lastic-side keyway

Example: Order number 4 / 494.624.0 / 50 / 50 plus limit switch 055.002.5

Technical explanations

Indicated torque adjustment

The EAS[®]-Compact torque limiting clutch offers the comfort of the indicated torque adjustment at the adjusting nut. The possibility for indication offers a substantially simplified torque adjustment and a simple monitoring of the set releasing value with an installed clutch.

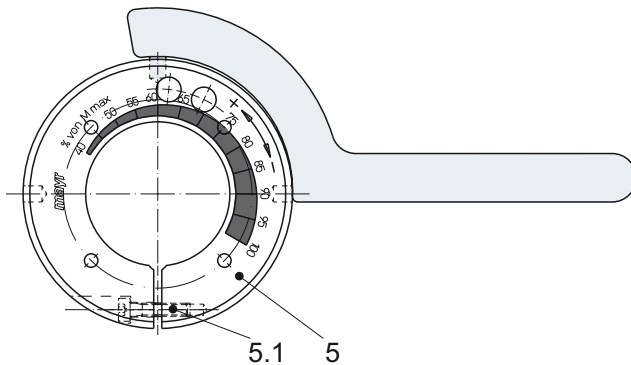

Fig. 1

Torque adjustment

The adjustment is made by turning the adjusting nut. The cup springs operate in the negative area of their characteristics (see fig. 2). A stronger pre-tension of the cup springs effects a decrease of the spring pressure. Turning the adjusting nut in a clockwise direction reduces the torque, and in anti-clockwise direction increases the torque (viewed in the direction of the nut - figure 1).

EAS[®]-Compact are adjusted **generally** at 70% - 75% of the corresponding max. torque and marked (calibrated) at the factory, if no other torque adjustment is required.

Torque adjustment by the aid of the adjusting diagram

- Grease thread and contact faces of the adjusting nut, retaining ring and hub.
- Manually screw on adjusting nut (1) until contact is made with the cup springs (7).
- Continue turning until the 4 graduations (5) at the circumference of the adjusting nut (1) and the notches in the retaining ring (6) are in line with each other.
- Using a face wrench, turn the adjusting nut (1) through the number of graduations corresponding to the required torque (Fig. 3) (number of graduations as per setting diagram).
- The graduations at the circumference of the adjusting nut (5) and retaining ring (6) must remain in the same position.
- Put Loctite 242 onto the retaining screw (2) and screw it into the adjusting nut (1).

Attention!!

After dismantling the clutch (e.g. by changing the cup springs or cup spring layers) the clutch must be re-adjusted.

- The limiting torque can be adjusted sensitively and indicated exactly by the fine pitch threaded graduated adjusting nut.
- The positive locking of the adjusting nut protects against selfacting unintended adjustment of the pre-set limiting torque. The integral blocking protection prevents the clutch from becoming spring bound.

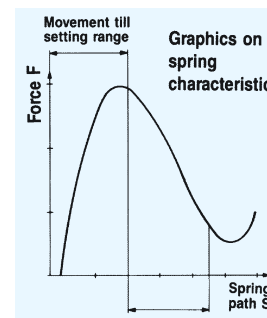

Fig. 2

Adjusting the torque

Remove the retaining screw (2) from the adjusting nut.

Turn adjusting nut clockwise or anti-clockwise with the use of a face wrench according to the engraved graduation until the required torque is set. The required torque is achieved when the graduation in the retaining ring and the indication on the percentage in the adjusting nut are overlapped. Afterwards the retaining screw or setscrew, respectively (locking by Loctite 242) are screwed into the adjusting nut again, whereby the 4 graduations in the adjusting nut and retaining ring must remain in the same position.

Example:

Existing adjustment 65% of the max. torque.
The customer requires 90% of the max. torque.

Turn adjusting nut anti-clockwise, as described above, until 90% of the graduation are in line with the notches in the retaining ring. If necessary, the alignment of the notches at the circumference of the adjusting nut must be overlapped with the graduations of the retaining ring.

Table: Relationship of the flexible coupling bore diameter d_3/d_4 to the transmittable torque "T_{KN}" of the EAS®-Compact Types 494._0._./ 494._1._.

Size	Preferred bores Ø d ₃ (clamping hub) / Ø d ₄ (shrink disc) and appropriate transmittable torques of the friction tight of the clamping hubs (with Type 494._0._.) / shrink discs (with Type 494._1._.)																			
	Ø 15		Ø 16		Ø 19		Ø 20		Ø 22		Ø 24		Ø 25		Ø 28		Ø 30		Ø 32	
	d ₃	d ₄	d ₃	d ₄	d ₃	d ₄	d ₃	d ₄	d ₃	d ₄	d ₃	d ₄	d ₃	d ₄	d ₃	d ₄	d ₃	d ₄	d ₃	d ₄
01	34	66	36	71	43	86	45	92	50	102	54	113	57	118	63	120	-	-	-	-
0	-	-	-	-	79	174	83	184	91	205	100	225	104	235	116	266	124	286	133	307
1	-	-	-	-	-	-	83	255	91	283	100	311	104	326	116	368	124	397	133	426
2	-	-	-	-	-	-	-	-	-	-	-	-	-	-	116	420	124	460	133	500
3	-	-	-	-	-	-	-	-	-	-	-	-	-	-	-	-	-	-	-	on request

Size	Ø 35		Ø 38		Ø 40		Ø 42		Ø 45		Ø 48		Ø 50		Ø 52		Ø 55	
	d ₃	d ₄	d ₃	d ₄	d ₃	d ₄	d ₃	d ₄	d ₃	d ₄	d ₃	d ₄	d ₃	d ₄	d ₃	d ₄	d ₃	d ₄
	01	-	-	-	-	-	-	-	-	-	-	-	-	-	-	-	-	-
0	145	320	-	320	-	-	-	-	-	-	-	-	-	-	-	-	-	-
1	145	470	158	515	166	544	174	580	187	650	-	-	-	-	-	-	-	
2	145	563	158	627	166	670	174	714	187	770	-	820	-	900	-	-	-	
3	on request																	

Table 1 The transmittable torque with clamping connection takes into account the max. fit with shaft tolerances k6/bore tolerances F7 or H7. With larger tolerances and fits the torque will decrease.

Dimensions



Ind. Cont. Eq.
LISTED 1B68

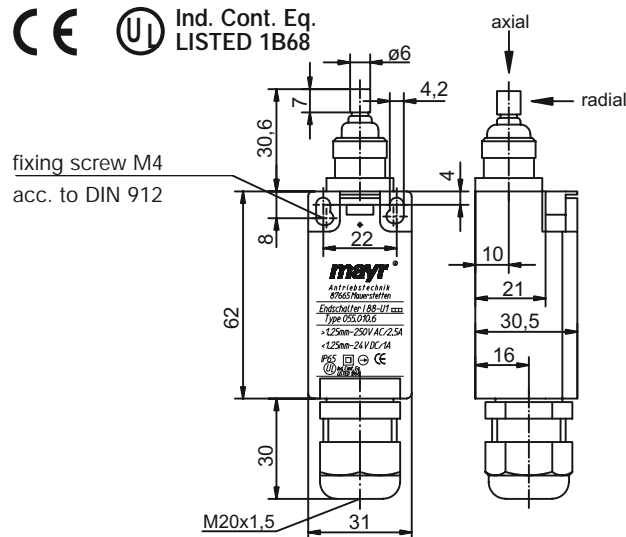

Assembly

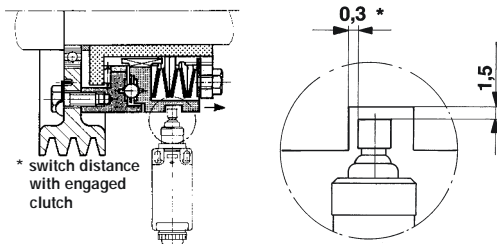

Attention! Do not fit switch in a dragging way and observe max. actuation travel (4 mm).

Wiring diagram

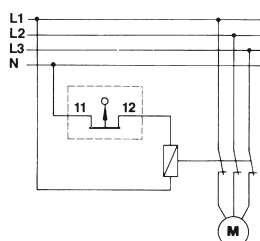

Switching travel diagram

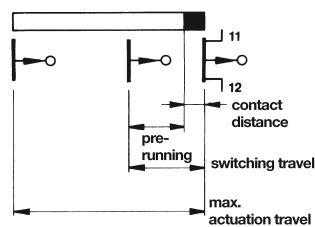

Application and Function

Monitoring of universal, mechanical movements and adjustments. Suitable for clutches with a minimum stroke of
- 1,1 mm with radial actuation
- 0,9 mm axial actuation

By actuating the metal rod the contacts 11-12 are opened. Zb: contacts separated by force, electrically disconnected.

Technical data

- Contact: 1 x opener (Zb) -> automatic separation of the opener contact acc. to EN 60947-5-1
- Contact opening: - after 0,2 - 0,4 mm with radial actuation
- after 0,1 mm with axial actuation
- Load opener-contact: contact-distance > 1,25 mm = 250 VAC/2,5 Amp.
contact-distance < 1,25 mm = 24 VDC/1 Amp. (min. contact - distance 0,5 mm with 24 VDC)
- Max. current at make: acc. to EN 60947-5-1
AC 15 - control electromagnetic force
DC 13 - control of electromagnets
- Max. actuating travel of the metal tappet: 4 mm, axial or radial
- Switching frequency: max 100/min.
- Mech. service life: 1 x 10⁶ hysteresis, unloaded
- Cable gland: M20 x 1,5
- Max. connection cross section: 1,5 mm²
- Ambient temperature: - 30 °C up to + 80 °C
- Protection: IP 65
- Protection insulation: acc. to protection class II
- Housing: thermoplastic, self extinguishing to UL94-V0
- Weight: approx. 120 g

Approvals/Standards

- UL
- CE
- EN 60529: protection
- EN 60204: protection of machines
- EN 60947-1: - electrical equipment of machines -
- EN 60947-5-1: low voltage switch gears
- EN 60947-5-1: - general definitions -
- EN 60947-5-1: low voltage switch gears
- EN 60947-5-1: - control units and control elements -

Order example

To be included when ordering, please state:	Type
Order number:	055.010.6

Limit switch - proximity sensing

Type 055.001.5

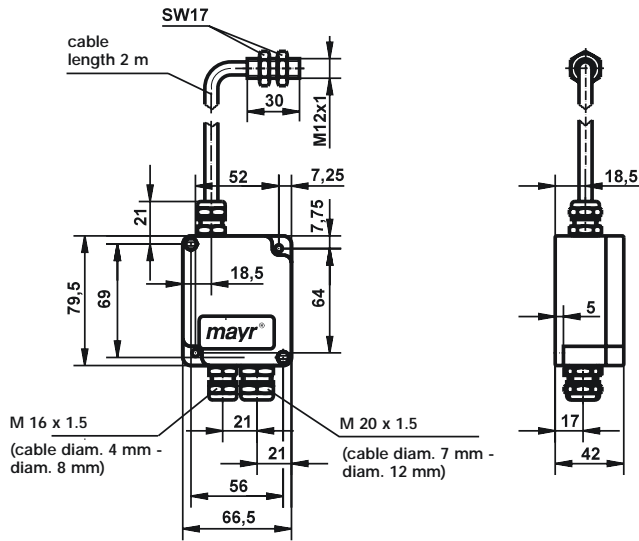

– external NAMUR-sensor to EN 50227

Design

- Amplifier:** – in light metal housing
- NAMUR-sensor:** – metal housing M 12 x 1
– switching distance SN 2 mm, flush fitting
– max. switching frequency 2 kHz
– cable length 2 m, standard, (max. 100 m, special design)
- Contact load:** – potential free change over contacts 1-2-3 max. 230 VAC/5 Amp.
- Monitoring against breakage of the cable of the NAMUR-sensor**

Technical data:

- Supply voltage:** 230 VAC, +/-10 %, 50-60 Hz
115 VAC, +/-10 %, 50-60 Hz
24 VDC, +/-5 %, independent polarity
- Input:** 1,5 VA
- Ambient temperature:** amplifier -10° C up to +60 °C
NAMUR-sensor -25° C up to +60 °C
- Protection:** amplifier IP 54
NAMUR-sensor IP 67
- Connection cross section:** able to be connected max. 2,5 mm² (AWG 14)
- Weight:** 400 g

Motor runs, if: the contacts 1 – 2 are closed.

- Contacts are closed, if:
- the supply voltage is switched on and
 - the signal relay is energised and
 - the NAMUR-sensor is undamped

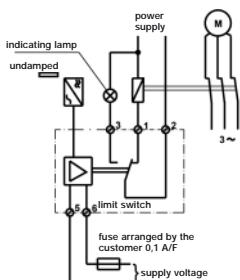

Motor does not run, if: the contacts 3 – 2 are closed.

- Contacts are closed, if:
- the supply voltage is switched-off or
 - the signal relay is de-energised or
 - the NAMUR-sensor is damped or
 - a parting of a cable is in the sensor cable

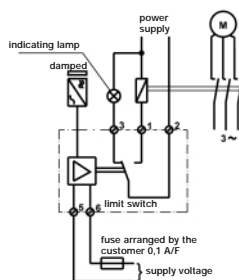

Type 055.002.5

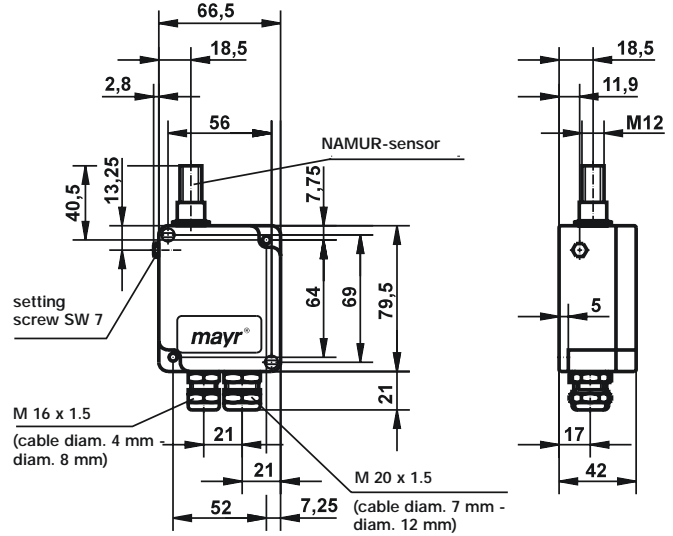

– internal NAMUR-sensor to EN 50227

Design

- Amplifier:** – in light metal housing
- NAMUR-sensor:** – fitted in light metal housing
– switching distance SN 2 mm, flush fitting
– max. switching frequency 2 kHz
- Zero shift:** – possible zero shift by 1 mm each via hexagon screw SW 7
- Contact load:** – potential free change over contacts 1-2-3 max. 230 VAC/5 Amp.

Technical data:

- Supply voltage:** 230 VAC, +/-10 %, 50-60 Hz
115 VAC, +/-10 %, 50-60 Hz
24 VDC, +/-5 %, independent polarity
- Input:** 1,5 VA
- Ambient temperature:** -10 °C up to +60 °C
- Protection:** IP 54
- Connection cross section:** able to be connected max. 2,5 mm² (AWG 14)
- Weight:** 400 g

Design

The electronic amplifier is fitted into a light metal housing. The limit switch is fastened via two screw-on brackets attached diagonally with M4 cap screws.

When the sensor surface of the NAMUR-sensor is scanned **-damped-** with a metallic control flag the signal relay is triggered, it gets **de-energised** and drops. Contacts 1 – 2 are open. The damping of the NAMUR-sensor is possible from all around.

Order example

To be included when ordering, please state:	Type	Supply voltage
Order number:	055.00_ . 5	---

- Internal NAMUR-sensor 2 →
- External NAMUR-sensor 1 →

Example: limit switch proximity sensing with an external NAMUR-sensor and a supply voltage of 230 VAC.

Order number: 055.001.5/230 VAC

Acceptances: for Type 055.001.5 and 055.002.5

UL-standard UL 508

CSA standard C22.2 No. 14-M 91

Worldwide representation

Headquarters

Chr. Mayr
GmbH + Co. KG
Eichenstrasse 1
D-87665 Mauerstetten
Tel.: 49-83 41/8 04-241
Fax: 49-83 41/804422
<http://www.mayr.de>

Great Britain

Mayr Transmissions Ltd
Valley Road, Business Park
GB-Keighley, BD21 4LZ
West Yorkshire
Tel.: 0 15 35/66 39 00
Fax: 0 15 35/66 32 61
sales@mayr.co.uk

Italy

Mayr Italia S.r.l.
Viale Veneto, 3
I-35020 Saonara (PD)
Tel.: 0 49/8 79 10 20
Fax: 0 49/8 79 10 22
info@mayr-italia.it

France

Mayr France S.A.
Z.A.L. du Minopole
BP 16
F-62160 Bully-Les-Mines
Tel.: 03/21.72.91.91
Fax: 03/21.29.71.77
contact@mayr.fr

Switzerland

Mayr Kupplungen AG
Tobelackerstrasse 11
CH-8212 Neuhausen
am Rheinfall
Tel.: 0 52/6 74 08 70
Fax: 0 52/6 74 08 75
info@mayr.ch

USA

Mayr Corporation
4 North Street
USA-Waldwick
NJ 07463
Tel.: 2 01/4 45-72 10
Fax: 2 01/4 45-80 19
info@mayrcorp.com

Singapore

Mayr Transmission (S)
Pte. Ltd. – Blk 133
Jurong East Street 13
Unit 03-291
SGP-Singapore 600133 Asean
Tel.: 0065/65601230
Fax: 0065/65601000
mayr@pacific.net.sg

Korea

Mayr Korea
P. O. Box 23
Changwon, Kyungnam
Rep. of Korea
Tel.: 055/262-4024
Fax: 055/262-4025
jplmk@nownuri.net

Taiwan

(for machine tool manuf.)
German Tech Auto Co., Ltd.
No. 58, Wu Chuan Road
Wu-Ku Industrial Park
RC-Taipei Hsien, Taiwan
Tel.: 02/22990237
Fax: 02/22990239
steve@zfgta.com.tw

China

Driveline Technology
Co., Ltd.
Weihai Road 350
Room 401 – 403
200041 Shanghai
Tel.: 021/6267-9779/-3599
Fax: 021/6267-2190
dtcshanghai@online.sh.cn

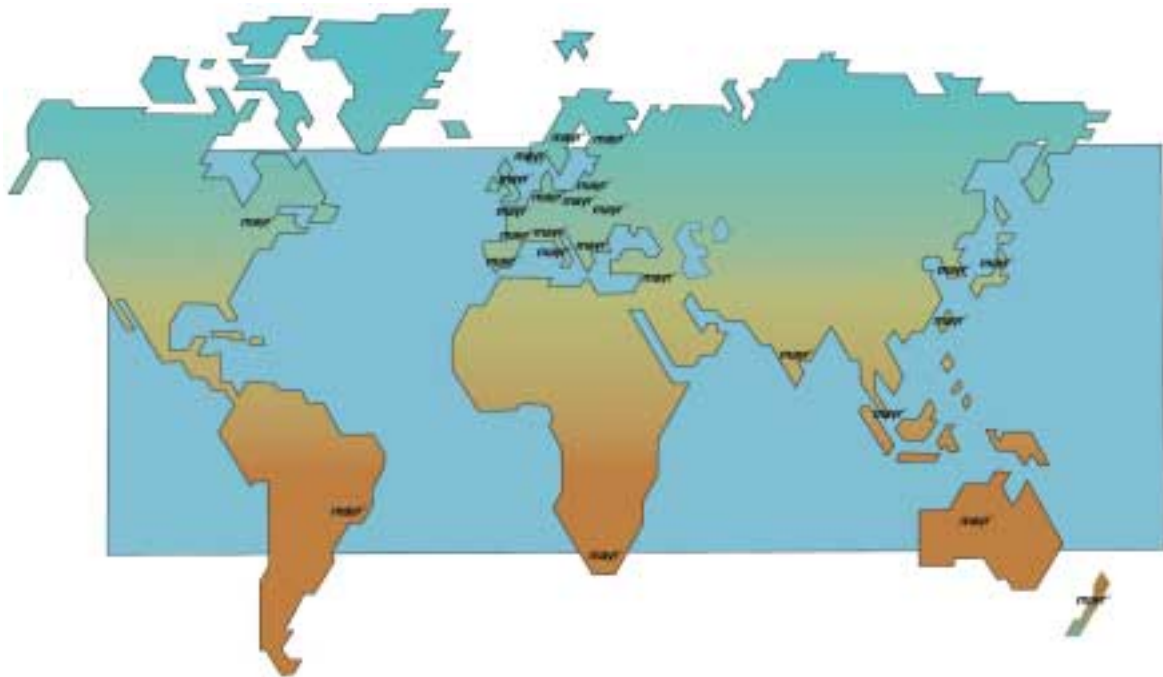

Australia

Reynolds
Dynamics Pty. Ltd.
1B/310 Boundary Road
Dingley 3172, VIC
AUS-Melbourne
Tel.: 039/551 6633
Fax: 039/551 6725
sales@reynoldsdynamics.com.au

New Zealand

Saeco A.D.I.Ltd.
36 Hastie Avenue
Mangere East
P. O. Box 22-256
NZ-Otahuhu-Auckland
Tel.: 09/634 7540
Fax: 09/634 2023
grant@saeco.co.nz

India

National Engineering
Company (NENCO)
J-225, M.I.D.C. Bhosari
IND-Pune 411 026
Tel.: 020/7474529
Fax: 020/7470229
nenco@vsnl.com

Japan

Shinwa Trading Co. Ltd.
1-3, 3-Chome
Goko-Dori, Chuo-ku
Kobe City
Tel.: 078/2512311
Fax: 078/2652676
ohta@shinwa-kobe.co.jp

South Africa

Torque Transfer
Private Bag 9
ZA-Elandsfontein 1406
Tel.: 011/3922771
Fax: 011/3922561
torque@bearings.co.za

Austria

Benelux States

Brazil

Canada

Czech Republic

Denmark

Finland

Greece

Hongkong

Hungary

Indonesia

Israel

Malaysia

Norway

Philippines

Poland

Russia

Slovakia

Slovenia

Spain

Sweden

Thailand

Turkey

Note:

If a country is not shown, please refer to headquarters or our web site to be advised of the nearest responsible agent.

mayr[®]
your reliable partner

Delivery Programme



Safety clutches/ torque limiters

- ❑ **EAS®-Compact/EAS®-NC**
Backlash-free, positive safety clutches
- ❑ **EAS®-standard**
Positive safety clutch with backlash
- ❑ **EAS®-overload/EAS®-elements**
Modular overload clutch for heavy duty applications
- ❑ **EAS®-axial**
Overload protection for linear movements
- ❑ **EAS®-Sp/EAS®-Sm/EAS®-Zr**
Pneumatically or electromagnetically controlled torque limiting clutches with ON/OFF control
- ❑ **ROBA®-slip hubs**
Load holding, friction type safety clutches



Shaft couplings

- ❑ **smartflex®**
Precision shaft coupling for servo applications, direct drive systems and stepping motors
- ❑ **ROBA®-DX**
Backlash-free, torsionally rigid flexible steel bellows coupling
- ❑ **ROBA®-ES**
Backlash-free and flexible for vibratory critical drives
- ❑ **ROBA®-DS**
Backlash-free, torsionally rigid and shock-proof all-steel flexible coupling
- ❑ **ROBA®-D**
Backlash-free, torsionally rigid all steel flexible coupling



Electromagnetic brakes/clutches

- ❑ **ROBA-stop® safety brakes**
Electromagnetic spring applied safety brakes
- ❑ **ROBA-stop®-M motor brakes**
Electromagnetic spring applied safety brakes
- ❑ **ROBA-stop®-Z dual circuit fail safe brakes**
Double security or double braking torque
- ❑ **ROBA®-quick brakes**
Electromagnetic pole face brakes
- ❑ **ROBATIC®-clutches**
Electromagnetic pole face clutches
- ❑ **ROBA®-takt**
Clutch brake units